

PATTE DE FIXATION EXTERIEURE (OPTION)
4 TROUS DE FIXATION Ø10
EXTERNAL MOUNTING BRACKETS (OPTION)
4 FIXING HOLES Ø10

4 TROUS Ø6.5 FIXATION INTERIEURE
4 HOLES Ø6.5 MOUNTING MADE FROM INSIDE

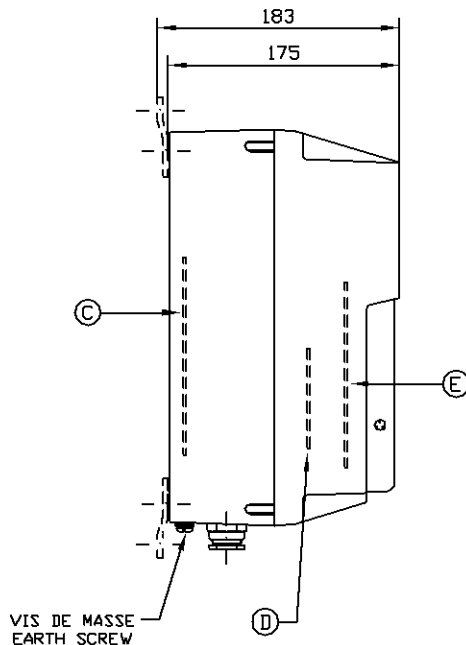

(B) 2 ENTREES DE CABLE LIVREES NON MONTÉES (VOIR NOTA)
2 CABLE ENTRIES SUPPLIED BUT NOT MOUNTED (SEE NOTA)

NOTA: POSTE FOURNI AVEC UNE POCHETTE CONTENANT:

- 2 BOUCHONS D'OBSTRUCTION
- 1 ENTREE DE CABLE TYPE ESL16C12*14 POUR CABLE Ø12 A 14 MAXI
- 1 ENTREE DE CABLE TYPE ESL11C8*10 POUR CABLE Ø8 A 10 MAXI
- 1 BOUCHON REDUCTEUR PE16/PE11

NOTA: STATION IS DELIVERED WITH BAG WHO INCLUDES:

- 2 SEALING CAPS
- 1 CABLE ENTRY TYPE ESL16C12*14 FOR Ø12/14 MAX CABLE
- 1 CABLE ENTRY TYPE ESL11C8*10 FOR Ø8/10 MAX CABLE
- 1 CABLE ENTRY REDUCER PE16/PE11

**BORNIER
CONNECTING BLOCK**

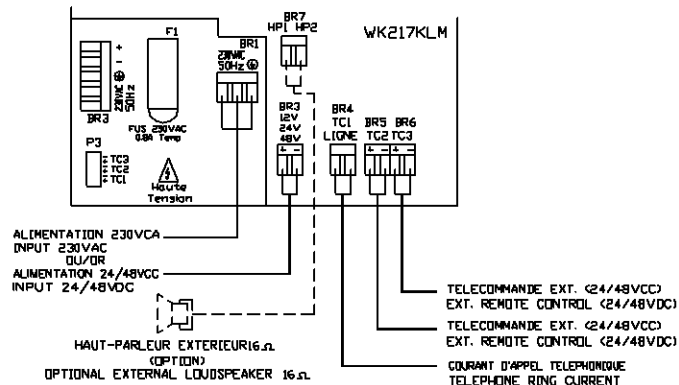

ALIMENTATION 230VCA
INPUT 230VAC
OU/OR
ALIMENTATION 24/48VCC
INPUT 24/48VDC

HAUT-PARLEUR EXTERIEUR 16Ω
(OPTION)
OPTIONAL EXTERNAL LOUDSPEAKER 16Ω

TELECOMMANDE EXT. (24/48VDC)
EXT. REMOTE CONTROL (24/48VDC)
TELECOMMANDE EXT. (24/48VDC)
EXT. REMOTE CONTROL (24/48VDC)
COURANT D'APPEL TELEPHONIQUE
TELEPHONE RING CURRENT

CONSTRUCTEUR Manufacturer	LE LAS	31/26 R Roger SALENOD 13413 FONTENAY/BOIS
MATIERE: Material	EXECUTION: Execution	Échelle/Draw Plan
		1/40
		34/E-ENC
		Rev.
		SGV934E6CA/CC
		VERIFIE Checked
		APPROUVE Approved
		DATE Date
		28/07/97
		05/07/97
		17/08/93
		REV. ÉTABLI REV. ESTABLISHED
		REV. MODIF. REV. MODIFIED
		REV. DISJONCTION/REV. DISJUNCTION
		REV. MISE A JOUR REV. UPDATING
		REV. MODIF. CONNECT-REF REV. MODIFIED CONNECT-REF

DESCRIPTION:

CARTER CONSTITUE D'UNE BOITE ET D'UN COUVERCLE EN METAL LEGER PROTEGE PAR PEINTURE EPOXY PG13. LA FERMETURE DU COUVERCLE A CHARNIERES S'EFFECTUE PAR 4 VIS CHC M6 EN ACIER INOX, TETES NOYÉES DANS UNE ALVEOLE. CE CARTER COMPREND:

- (A) 1 MOTEUR DE HAUT PARLEUR CE225V7
- (B) ENTREES DE CABLE (VOIR NOTA)
- (C) 1 CARTE HURLEUR WK217KLM
- (D) 1 CARTE CONVERTISSEUR WK042CFF
- (E) 1 CARTE FEU FLASH WK156FEF

REFERENCE: SGV 344 E6 CA/CC

DESCRIPTION:

CASING CONSISTING OF A BOX AND COVER OF LIGHT ALLOY PROTECTED BY EPOXY PAINT PG13. THE HINGED COVER IS CLOSED BY 4 SCREWS CHC M6 IN STAINLESS STEEL WITH HEAD EMBEDDED IN A RECESS. THIS CASING INCLUDES:

- (A) 1 LOUDSPEAKER'S MOTOR CE225V7
- (B) CABLE ENTRIES (SEE NOTA)
- (D) 1 HOWLER CARD WK217KLM
- (E) 1 CONVERTOR CARD WK042CFF
- (F) 1 FLASHING CARD WK156FEF

REFERENCE: SGV 344 E6 CA/CC