



METAL COLUMN LOUDSPEAKER

MCS20T/EN

This two-way metal sound column combines elegant styling, robust design and high performance. It is characterized by a very wide frequency range, which is reflected in the high-quality reproduction of speech and music, in contrast to conventional tone columns.

The high sound pressure achieved by a special high-pressure driver's horn and the special radiation characteristics make the column ideal for use in rooms that are difficult to be sonicated like airports, churches, factories, sports halls, conference rooms, etc. At the bottom is a variable power regulator for the individual adjustment of the required power.



EN54-24:2008 0905-CPR-201107 TYPE B

● Standard	Compliant to EN54-24 Compliant to BS5839:8
● Electrical	
Rated power, Watts	20
Tappings 100 Volt line, Watts	20/10/5/2.5
Transformer Impedance, Ohms 100 Volt	500/1k/2k/4k
Tappings 70.7 Volt line, Watts	10/5/2.5/1.25
Driver impedance, Ohms	2
Effective Frequency Range, Hz (BSEN60268-5)	170-17.000
S.P.L. @ 1 m, 1 Watt, dB, Octave, 100 Hz-10 kHz	92
S.P.L. @ 1 m, Full power, dB, Octave, 100 Hz-10 kHz	105
S.P.L. @ 4 m, 1 Watt, dB, 1/3 Octave, 100 Hz-10 kHz	78
S.P.L. @ 4 m, Full power, dB, 1/3 Octave, 100 Hz-10 kHz	90
Dispersion at 1k/2k Hz, Degrees	179/140 Horizontal 100/28 Vertical
● Environmental	
IP Rating	55
Min/Max Ambient Temp	-25°C to 70°C
Relative Humidity	≤95%
● Mechanical	
Dimensions, front & depth, mm	368 x 98 x 90
Net weight, kg	2.5
Colour (Unless Specified)	White, RAL9016
Material	Aluminium
Mounting	Steel L bracket, optional swivel bracket
Safety	Ceramic Block Thermal Fuse



ATEIS Europe B.V.
Celsiusstraat 1, 2652 XN Lansingerland, Netherlands
Phone +31 (0)10 208 86 90, www.ateis-europe.com, info@ateis-europe.com





INSTALLATION GUIDE

MCS20T/EN

EN54-24:2008
0905-CPR-201107
TYPE B

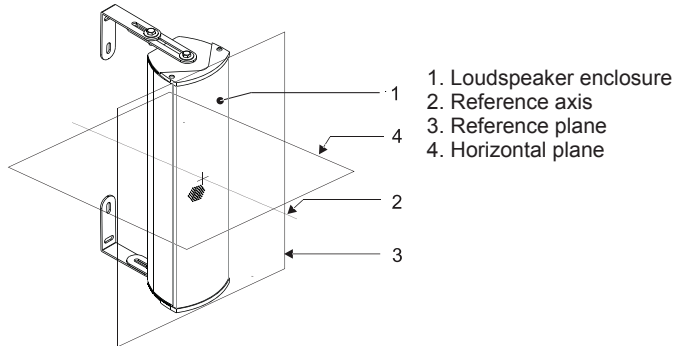

Top view
(unit: mm)

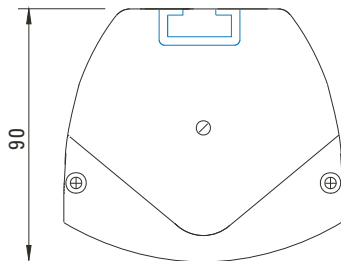

With Transformer:
100V/70V line

	White wire plus tapping					Black
	2.5W	5W	10W	20W	OFF	COM
100V	2.5W	5W	10W	20W	OFF	COM
70V	1.25W	2.5W	5W	10W	OFF	COM
IMP (Ω)	4K	2K	1K	500	∞	

Front view
(unit: mm)

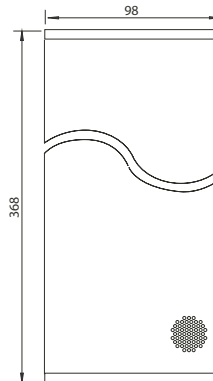

Frequency response

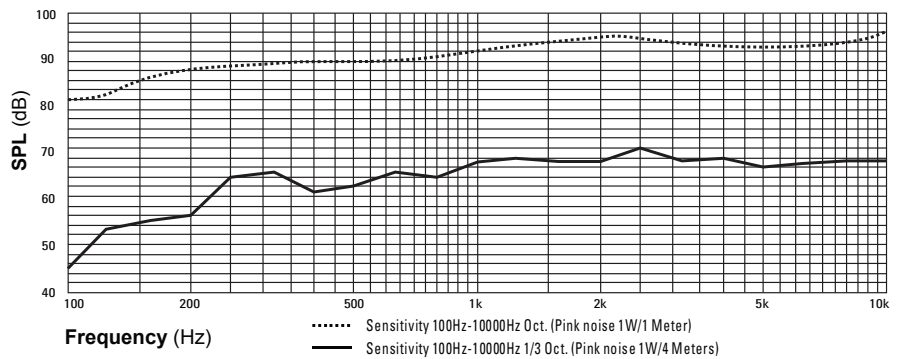

*Active Equalizer Applied: NO

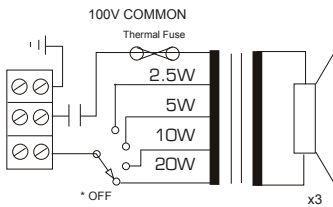

Circuit Diagram



ATEiS Europe B.V.
Celsiusstraat 1, 2652 XN Lansingerland, Netherlands
Phone +31 (0)10 208 86 90, www.ateis-europe.com, info@ateis-europe.com



INSTALLATION GUIDE

MCS20T/EN

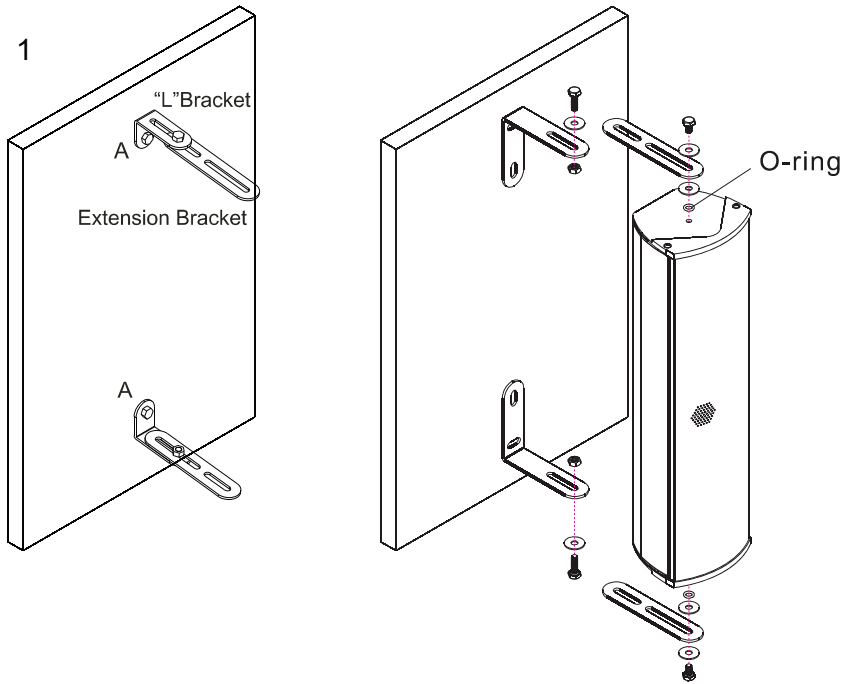

1) Mount the top & bottom "L" brackets by drawing a vertical line onto the wall. Each "L" bracket has an outer and inner mounting hole aligned vertically. The centre of the outer holes are 349 mm apart and the inner holes are 250 mm apart. Mark these positions at the required mounting height on to the vertical line. Align both brackets and double check the fixing points. Fix both brackets securely using suitable fixings (Not supplied). The "L" brackets are supplied with extender plates which can be used at the top to aim the speaker downwards or both top and bottom to mount the speaker further away from the wall. The extender plates are supplied with the speaker as a kit with the "L" brackets and hardware.

2) Remove the top cover from the speaker, this is located close to the cable entry. The installation cable can be fitted via a suitably rated gland into the 1 x 20 mm gland entry provided.

3) The cable can then be terminated into the terminal block located just below the top cover. The terminals are suitable to take "loop in"/"loop out" connections up to 2.5 mm per core.

4) Re-fit the rear cover ensuring that the gasket is in place and that the screw fittings are fitted with their rubber washers to ensure the top cover retains its weatherproof rating.

5) Mount the speaker to the "U" bracket using the M10 bolts provided at the top & bottom of the speaker. Position the speaker to the desired angle then tighten the fixings to secure in place.

6) The tapping can be adjusted via a recessed selector located at the bottom of the speaker. Use a flat bladed screw driver and insert it into the hole. Rotate the screw driver to select the desired tapping. See the label for tapping details.

Top View of Column Loudspeaker with lid off

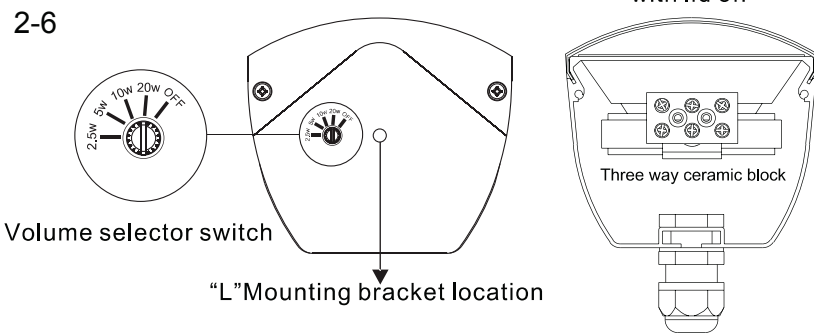

Disclaimer: We reserve the right of changes and errors.

