



VANDALPROOF METAL CABINET LOUDSPEAKERS

SENTRY6RT/ENC



The SENTRY6RT/ENC is a round, anti-vandal protected metal housing speaker, made of high-quality plastic coated quality steel. It contains a special chassis covering a wider frequency range, making it ideal for both good voice and high quality music reproduction. The robust and aesthetic SENTRY6RT/ENC can work on both fixed ceilings as well as on walls. supplied with two pre-punched shots for cable glands. It offers the installer the opportunity of looping through and can thus save time and costs during assembly.



EN54-24:2008 0905-CPR-201106 TYPE A

● Standard	Compliant to EN54-24 Compliant to BS5839:8
● Electrical	
Rated power, Watts	6
Tappings 100 Volt line, Watts	6/3/1.5/0.75/0.25
Transformer Impedance, Ohms 100 Volt	1.67k/3.33k/6.66k/13.3k/40k
Tappings 70.7 Volt line, Watts	3/1.5/0.75/0.375/0.125
Driver impedance, Ohms	8
Effective Frequency Range, Hz (BSEN60268-5)	250 - 18,000
S.P.L. @ 1 m, 1 Watt, dB, Octave, 100 Hz-10 kHz	95
S.P.L. @ 1 m, Full power, dB, Octave, 100 Hz-10 kHz	102
S.P.L. @ 4 m, 1 Watt, dB, 1/3 Octave, 100 Hz-10 kHz	81
S.P.L. @ 4 m, Full power, dB, 1/3 Octave, 100 Hz-10 kHz	86
Dispersion at 1k/2k Hz, Degrees	119/100 Horizontal 77/99 Vertical
● Environmental	
IP Rating	52
Min/Max amb temp	-10°C to 55°C
Relative Humidity	≤95%
● Mechanical	
Dimensions, Front Dia x D mm	Ø194 x 75
Net weight, kg	1.5
Colour (Unless Specified)	White, RAL9016
Material	Steel front, die cast back box
Mounting	Screws
Safety	Ceramic Block Thermal Fuse Capacitor for DC line monitoring



ATEIS Europe B.V.
Celsiusstraat 1, 2652 XN Lansingerland, Netherlands
Phone +31 (0)10 208 86 90, www.ateis-europe.com, info@ateis-europe.com





PENTON

INSTALLATION GUIDE

SENTRY6RT/ENC

EN54-24:2008
0905-CPR-201106
TYPE A

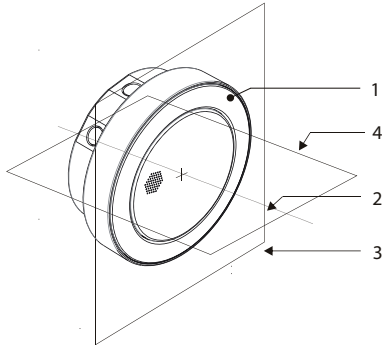
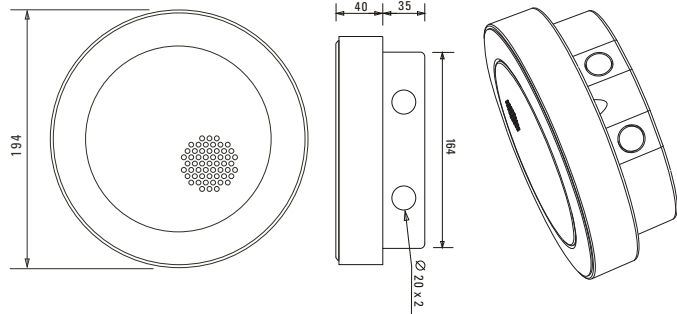

1. Loudspeaker enclosure
2. Reference axis
3. Reference plane
4. Horizontal plane

**With Transformer:
100V/70V line**

	White wire plus tapping						Black
100V	0.25W	0.75W	1.5W	3W	6W	COM	
70V	0.125W	0.375W	0.75W	1.5W	3W	COM	
IMP (Ω)	39.9K	13.3K	6.66K	3.33K	1.67K		

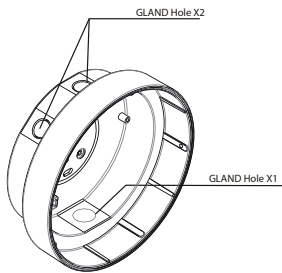

1) Decide on the back box orientation. Normally the back box is installed with the 2 x 20mm knockouts facing upwards. However the back box can be installed in any orientation as well as horizontally on a ceiling if required.

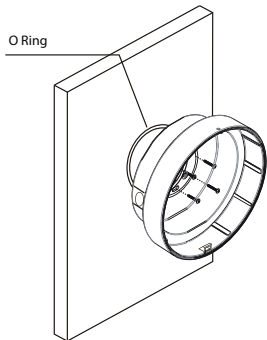

2) The back box has the option of glanding cable directly into any of the 3 x 20mm knockouts or through the rear of the cabinet.

3) Secure the back box to a flat surface using the fixing holes provided. (Fixings are not included). Do not forget to fit the rubber "O" ring between the wall and back box before fixing to the wall. This will ensure that the screw fixings and any rear cable entry will be sealed from water ingress.

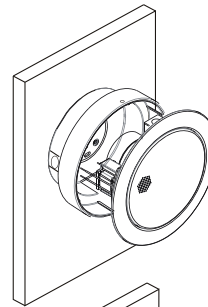

4) Once the back box has been fixed securely to the surface the installation cable can be fitted as required. The cable can then be terminated into the terminal block fitted to the back box. The terminals are suitable to take "loop in" "loop out" connections up to 2.5mm per core.

5) Take the speaker plate and connect the 3 pre-installed wires from the terminal block on the back box to the spade terminals provided on the speaker transformer.

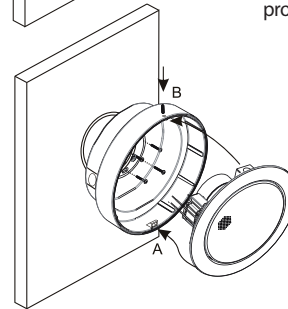

6) Slot the speaker plate on to the retaining lug 'A' and then push the speaker into the back box. Tighten the grub screw 'B' until it firmly holds the speaker plate. Be careful not to over tighten the grub screw.

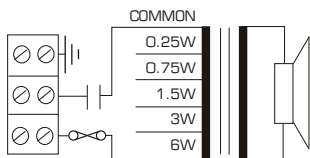

Circuit Diagram

Frequency response

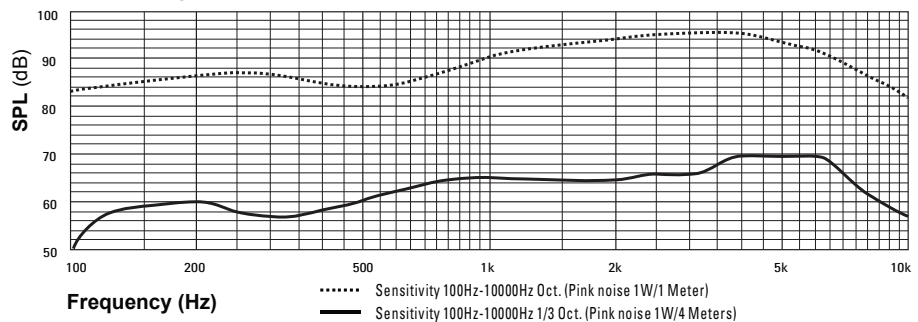

Disclaimer: We reserve the right of changes and errors.



ATEIS Europe B.V.
Celsiusstraat 1, 2652 XN Lansingerland, Netherlands
Phone +31 (0)10 208 86 90, www.ateis-europe.com, info@ateis-europe.com

